



INSTRUCTION MANUAL

REPTILE 1575

FREEDOM BREEDER



REPTILE 1575

INSTRUCTION MANUAL

REPTILE 1575
FREEDOM BREEDER



Product Description

This rack is made of 304 Stainless Steel, no rust ever!

When a breeder is ready to take his production to the next level, there's only one way to keep excessive amounts of baby reptiles.. the Freedom Breeder Reptile 1575 Baby Rack. Being able to keep 75 different hatchling snakes in such a small amount of space is the most efficient way to raise your babies. Upgrade to our FB10 tubs with cup holders, and amaze yourself with how fast you can clean 75 snakes. Still the most popular baby rack on the market, the Reptile 1575 will continue to make customers happy for years to come.

Caution

Channels and backstops have sharp edges, take precautions.

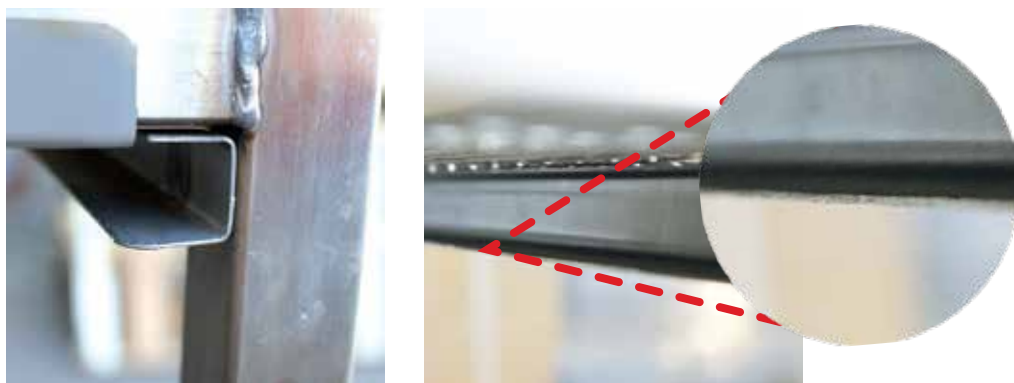

*Any comments or suggestions on this Instructions Manual please send us an email to manuel@freedombreeder.com

INSTRUCTION MANUAL

REPTILE 1575
FREEDOM BREEDER



Packing List

PART #	DESCRIPTION	QTY
1	Reptile 1575 Stainless Steel Levels	15
2	5" Heat Panels	15
3	FB10 Tubs	75
4	Base Frame	1
5	4" Heavy Duty Casters (Nuts and Bolts Included)	4

***Any extra items purchased can be found on your invoice.**
***Packing list may vary depending on your order.**

Requirements



1/2" Socket



Ratchet



Cutter



Gloves



Two persons
***Recommended**

INSTRUCTION MANUAL

REPTILE 1575 FREEDOM BREEDER



Assembly

STEP 1. Unwrapping

The Reptile 1575 is packed in a cardboard carton and plastic wrap for protection during shipment. Carefully unpack the items and remove the pallet.

Notice that the Reptile 1575 is almost assembled.

Note: If you detect any issue or damage please contact us before you accept the shipment.



STEP 2. Parts



Count all parts to make sure nothing is missing.

See Packing list for Descriptions and Quantities.

PART #	DESCRIPTION	QTY
1	Reptile 1575 Stainless Steel Levels	15
2	5" Heat Panels	15
3	FB10 Tubs	75
4	Base Frame	1
5	4" Heavy Duty Casters (Screws and Bolts Included)	4

Continue to step 3

INSTRUCTION MANUAL

REPTILE 1575
FREEDOM BREEDER



Assembly

STEP 3. Casters

Notice that the rack may or may not had the casters installed.

In case they have been installed, you just need to turn upside down the frame with the casters to the correct position.

In case the casters are not installed:

- 1.- Find the casters, nuts, and bolts.
- 2.- Insert the bolts into the holes in the lower frame.
- 3.- Using the ratchet and the 1/2" socket, tighten the caster with the bolts on each corner of the frame until the bolts are flush to the tubing of the frame.

Note: Make sure to put all the nuts and bolts included (3 per caster) and not overtighten the nuts.

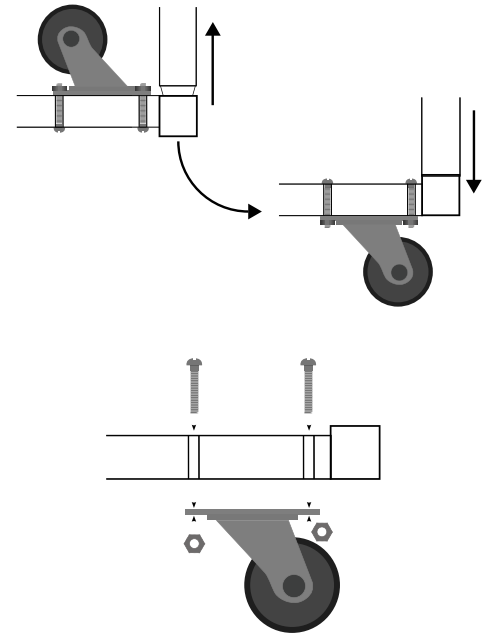

STEP 4. Stacking the levels

Stacked the levels over the base frame with the casters installed. You don't have to use tools on this step.

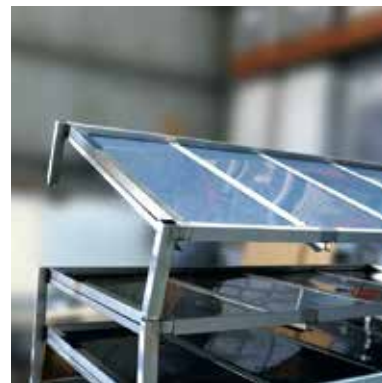

INSTRUCTION MANUAL

REPTILE 1575
FREEDOM BREEDER



Assembly

STEP 5. Trays

Insert the trays thru the channels on each level.

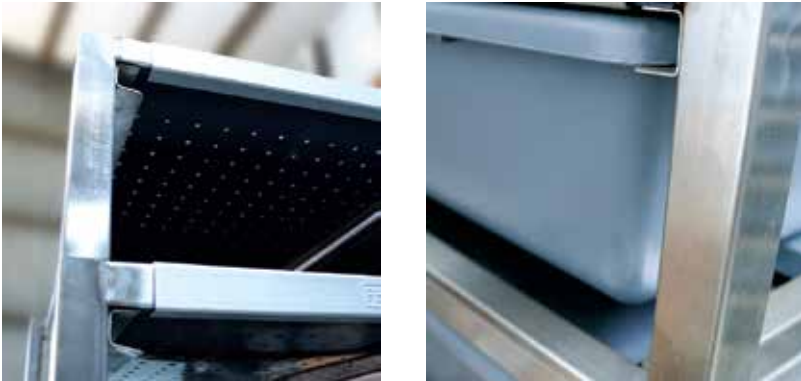

STEP 6. Heating system



***Insulated**

For the Heating system, place the heating panels over the velcro on each level, and connect the panel system to a source power.

Once all the heating panels are placed and plugged into the power strip, you will then plug your power strip into your thermostat or your FB-120 x2 and then plug it into the wall outlet.



INSTRUCTION MANUAL

REPTILE 1575
FREEDOM BREEDER



Assembly

If you purchased a power strip from us, you can either simply zip-tie each end to the side of the rack frame, or zip-screw each end to the rack frame.





Visit our Website, Instagram and Facebook page



www.freedombreeder.com



[@freedombreeder](https://www.facebook.com/freedombreeder)



[/freedombreeder](https://www.instagram.com/freedombreeder)



ATTENTION CUSTOMERS:

Please inform the appropriate personnel to always INSPECT YOUR SHIPMENT for damage PRIOR to signing the delivery receipt. If there is obvious damage, do not accept the shipment without NOTING IN DETAIL and taking pictures of the damage on ALL copies of the carrier's delivery receipt. Please have the freight driver SIGN ALL COPIES to acknowledge your damage notation.

-Thank You!

*Any comments or suggestions on this Instructions Manual please send us an email to manuel@freedombreeder.com
www.FreedomBreeder.com 209.664.9600 EXT. 201/202/203
Freedom Breeder · 2306 S. Daubenberger Rd. Turlock, CA 95380 USA